

Cat Series 4 Entrance Expansion Module

Installation / Setup Manual

CATDR4

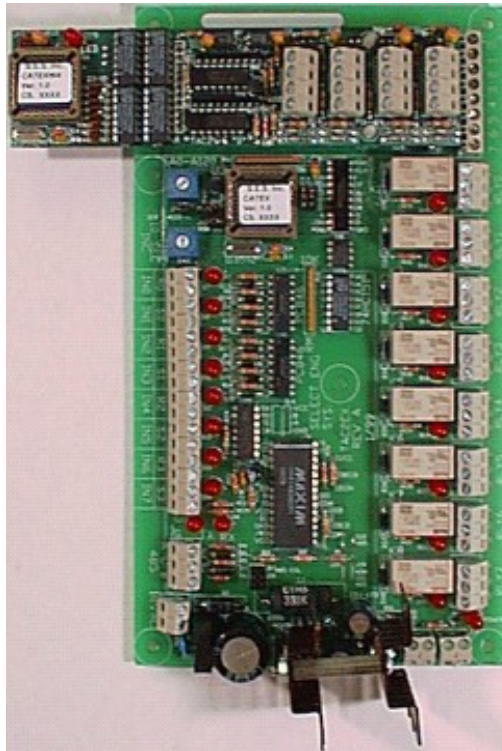

Select
Engineered
Systems, Inc.

CAT Series Auxiliary 4 Reader Module

This page left intentionally blank

Table of Contents

Cat Series Auxiliary 4 Reader Module

Introduction to Cat Series 4 Entrance Expansion Module	4
Description	4
Reader Module Addressing	5
Reader Activate Timing	6
REX input and alarm terminals	7
Output Terminals	7
Wiring Connections	8,9
Individual Relay Times	10
Index	11

CAT Series Auxiliary 4 Reader Module

The Select Engineered Systems
Cat Series 4 Entrance Expansion Module

The Cat Series 4 Entrance Expansion Module operates as a remote reader controller, with requests sent through a RS485 three wire loop from a CAT SERIES Unit ONLY. Wiegand inputs are sent to the CAT Card Access Unit where they are checked and will activate the correct entrance relays if authorized. The expansion module may be selected to Fail Secure or Fail Safe.

Fail Secure means the relays are normally de-energized and energize on command. When power fails the relays remain de-energized not allowing a command.

Fail Safe means the relays are normally energized and de-energize on command to open. When power fails the relays de-energize forcing the command to open.

A local terminal block provides for local activation of the REX (Request to Exit) and door sense inputs.

Each Cat Series 4 Entrance Expansion Module is individually assignable using a simple rotary switch to an address range in steps of four reader groups. The entire system allows for 3 boards to be connected for a maximum of 12 external readers. **Note: If two boards are set to the same address, the readers on BOTH boards would interact and the BOTH boards would NOT operate.**

The local terminal blocks provide opto-coupled control with the drive voltage provided. Terminals may be pulled to Circuit Common using dry relay contacts or opto-transistor pull downs with 100 ohms or less. LEDs (Light Emitting Diodes) are provided to indicate input and output conditions as well as RS485 activity.

The Cat Series 4 Entrance Expansion Module requires power at 18VAC / 40VA. The output relays are rated 3 amps at 24V ac/dc.

A 12"L x 11.5"W x 3.5"H NEMA 1 enclosure is standard.

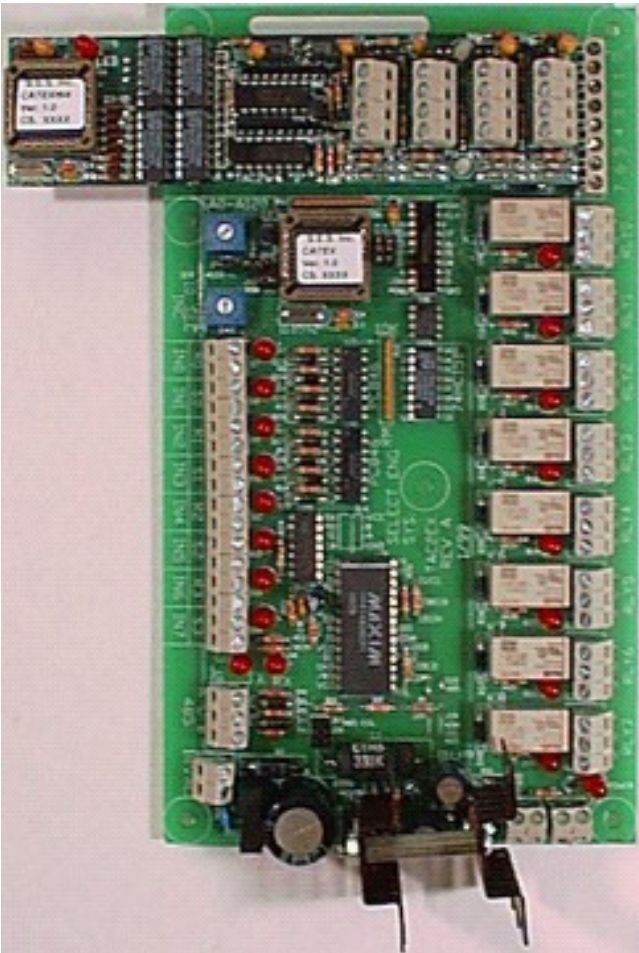

4 Entrance Module
PC Board

Standard Features for Cat Series 4 Entrance Expansion Module.

The Cat Series 4 Entrance Expansion Module contains an addressing selector 16 position rotary switch (SW1). This sets the address of the first reader code on the board and the other readers follow in consecutive order (Example: Switch Position 1 (shown) sets the activation codes as

- RLY0 = Reader 5 control,
- RLY1 = Reader 5 shunt,
- RLY2 = Reader 6 control,
- RLY3 = Reader 6 shunt,
- RLY4 = Reader 7 control,
- RLY5 = Reader 7 shunt,
- RLY6 = Reader 8 control
- RLY7 = Reader 8 shunt.

Note: J4 is not used and is disabled.

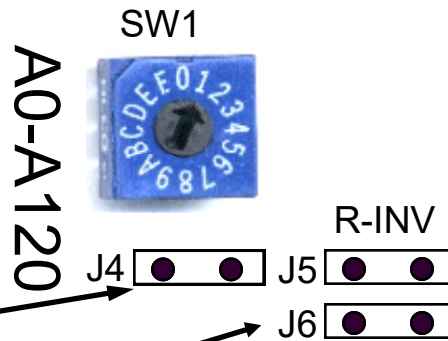

Addressing Selectors

J6-RDR INST—Reader Installed

J6 –OFF CATRLY8 Elevator Controller / NO Reader Installed

J6– ON CATDR4 Expansion Readers / Readers installed

Addressing Selector Switches		
Switch Position	First Reader Number	Last Reader Number
0	None	None
1	5	8
2	9	12
3	13	16
4 and above	None	None

The Cat Series 4 Entrance Expansion Module contains eight relay Form C outputs. Four entrance control relays and four alarm shunt relays. J5 set the relay action as J5-Off = Fail Secure (Relay is normally off and energizes on command) or J5-On = Fail Safe (Relay is normally on and de-energizes on command)

Note: R-Time is not used and is disabled.

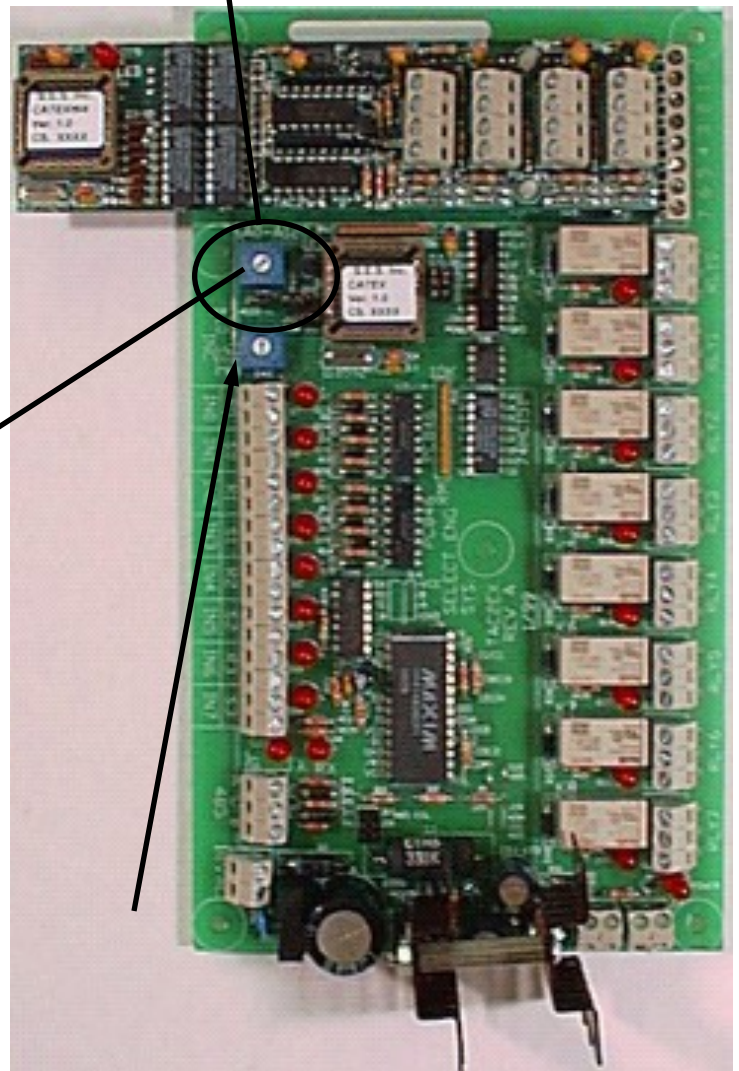

CAT Series Auxiliary 4 Reader Module

Typical Wiring for Wiegand Readers

Jumpers are shipped in the 12 volt position

Warning: If the jumper is moved to the 12V position and connected to a 5 Volt Reader, the reader will be damaged, and reader warranty are void.

Reader Power Selector Jumpers



Term	Reader
0	LED 5,9,13
2	LED 6,10,14
4	LED 7,11,15
6	LED 8,12,16

0	None	None	None	None
1	8	7	6	5
2	12	11	10	9
3	16	15	14	13
4 and above	N/A	N/A	N/A	N/A
Switch Position	Reader Entrance	Reader Entrance	Reader Entrance	Reader Entrance

Reader Locations

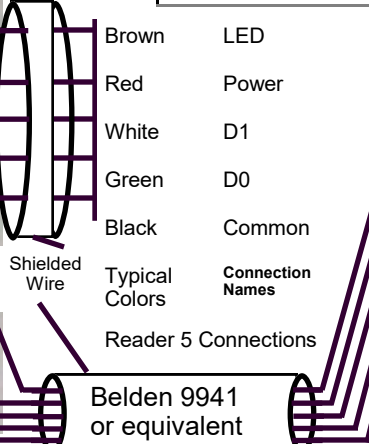
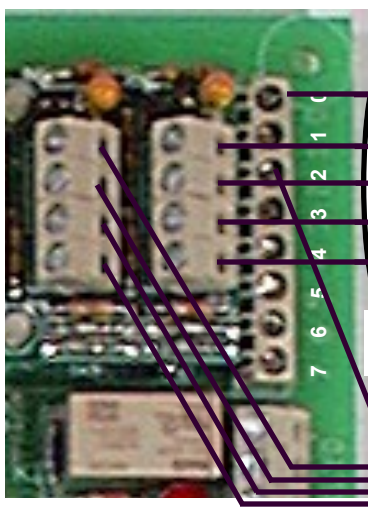

Note: Check reader documentation for proper wire colors for connections.



Standard Features for Cat Series 4 Entrance Expansion Module

April, 2008

The Cat Series 4 Entrance Expansion Module contains a terminal block (J16) that provides an logical low output for each relay output. They can be used to activate display LED's on the readers to indicate acceptance. The entrance indicated will depend on the setting of SW1.

The Cat Series 4 Entrance Expansion contains a terminal block (J3) to individually activate the REX (Request to Exit) and when the input terminals are shorted or pulled to common. You may use dry relay contacts or transistor pull-downs referenced to circuit common. Each input has a LED located just to the right of the terminals to indicate when that input is on.

When each input is closed the output relay will be activated for the time programmed by the Relay Timing Selector Switch and then the relay will return to its normal state *even if the input remains closed*.

Terminal ID	Terminal Description	(SW1) Entrance			Relay	Function
		1	2	3		
R0	REX	5, 9, 13			RLY0	Entr. Control
S0	Sense	5, 9, 13			RLY1	Alarm Shunt
R1	REX	6, 10, 14			RLY2	Entr. Control
S1	Sense	6, 10, 14			RLY3	Alarm Shunt
R2	REX	7, 11, 15			RLY4	Entr. Control
S2	Sense	7, 11, 15			RLY5	Alarm Shunt
R3	REX	8, 12, 16			RLY6	Entr. Control
S3	Sense	8, 12, 16			RLY7	Alarm Shunt

J7 located at the bottom of the board on the right side maybe used to turn off all the relays at once by opening the connection. This connector is normally shipped with a Jumper installed. This could be used with dry contacts opening on an external signal in conjunction with J5 settings (J5 connected is fail safe) to de-energize the relays during emergencies.

The relay outputs are type Form C (one normally open and one normally closed contact) rated at 3 amps 24 v ac/dc. Each relay has a LED (light emitting diode) next to it indicating when the relay is energized.

The BAT connections allow a backup battery to be connected. (SES Part No. B12V) This allows the unit to continue to operate during short power interruptions (approx 1 hour). Circuitry is included to charge and maintain the battery. **Note: Do not use these terminals to power other devices.**

Output	Entr.
0	5, 9, 13
2	6, 10, 14
4	7, 11, 15
6	8, 12, 16

Logical Output Block

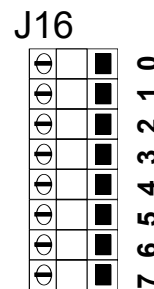

Logical Input Block

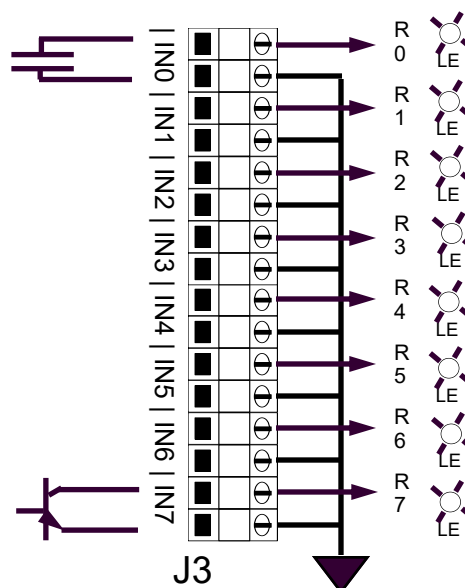

Common

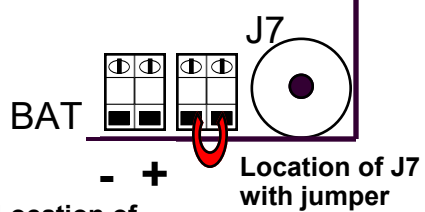

Location of BAT terminals with Polarity Marks

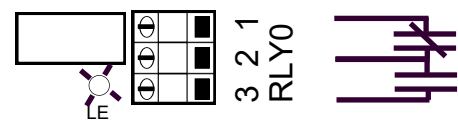

1-2 = N.C.
2-3 = N.O.
Example of relay output

CAT Series Auxiliary 4 Reader Module

Standard Features for Cat Series 4 Entrance Expansion Module.

Wiring and interconnections

Power: 18 vac at 40 va. Plug in transformer supplied with unit.
 Connect at **J1** with 18 GA wire to a maximum of 100 ft and 14 - 16 GA to 200 ft. Recommend using separate transformers for each unit for maximum noise isolation and protection.

RS485 connections: the Cat Series 4 Entrance Expansion Module communicates with **CAT Series Units only**, using isolated RS485 connections .

Recommended wire is Belden #8771. Attach from the CAT terminal barrier strip to J2 terminals as shown. Terminal 'A' is Red, Terminal 'C' is Black. Terminal 'B' is White. Note: Termination for the RS485 connections are provided. They must remain only on the LAST module connected. (If you are installing only one module, the Jumpers J17 J18 REMAIN).

Note: Entrance Modules and Auxiliary Relay Modules may be connected in the same RS485 line.

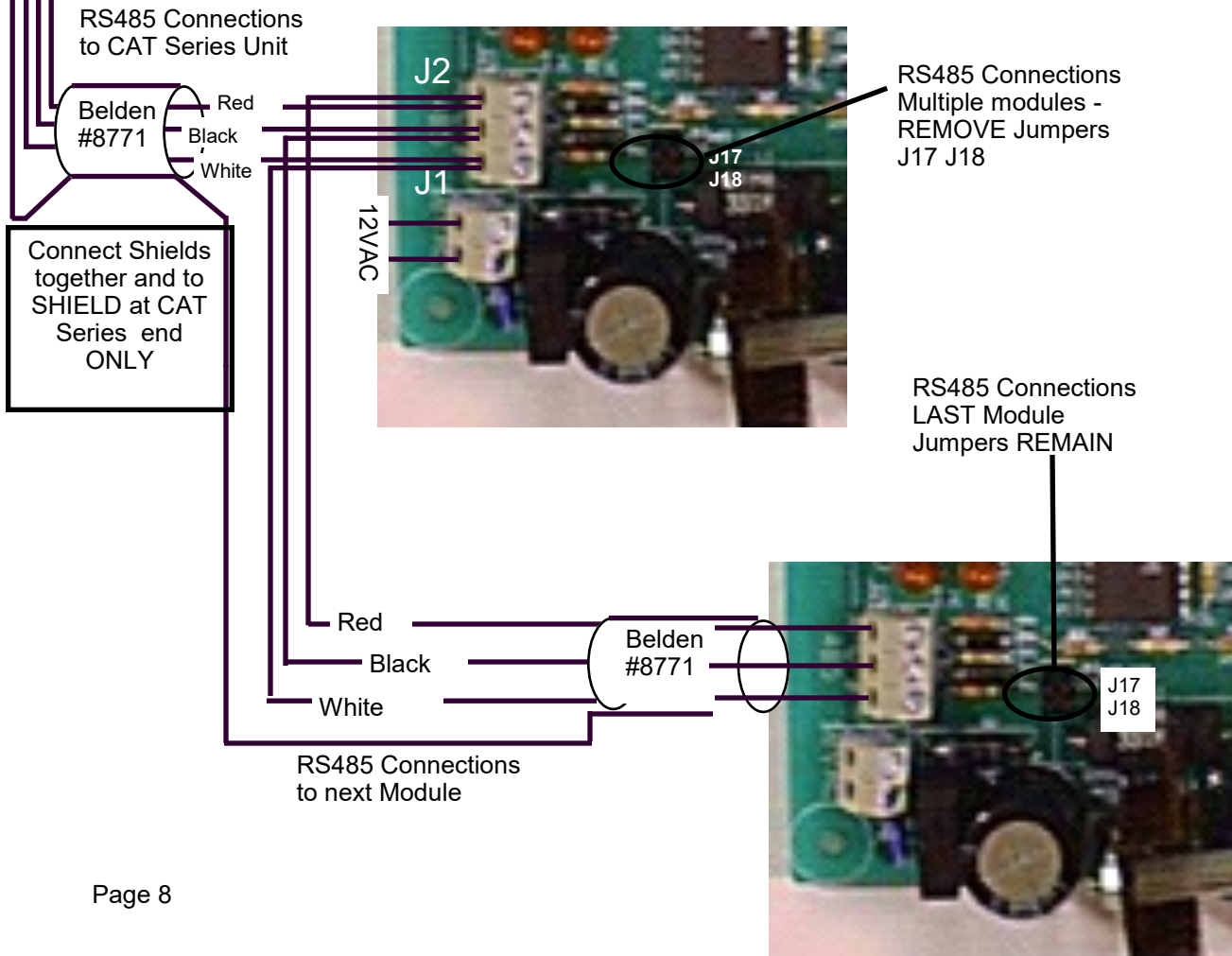
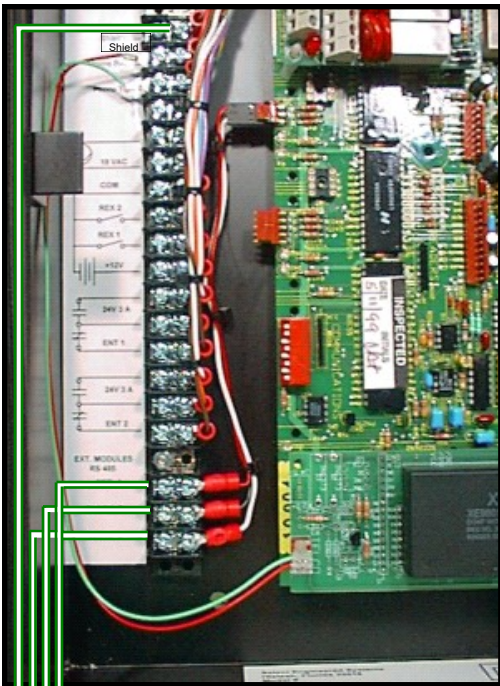

Cat Series 4 Entrance Expansion Module Terminal Locations and Wiring Connections

Addressing Selector Switches			
Switch Position	First Reader Number	Switch Position	Last Reader Number
0	None	0	None
1	5	1	8
2	9	2	12
3	13	3	16
4 and above	None	4 and above	None

Input Terminals and Function Entrance indicated follows SW1		
Terminal ID	Terminal Description	(SW1) Entrance 1 2 3
R0	REX Entr.	5, 9, 13
S0	Sense Entr.	5, 9, 13
R1	REX Entr.	6, 10, 14
S1	Sense Entr.	6, 10, 14
R2	REX Entr.	7, 11, 15
S2	Sense Entr.	7, 11, 15
R3	REX Entr.	8, 12, 16
S3	Sense Entr.	8, 12, 16

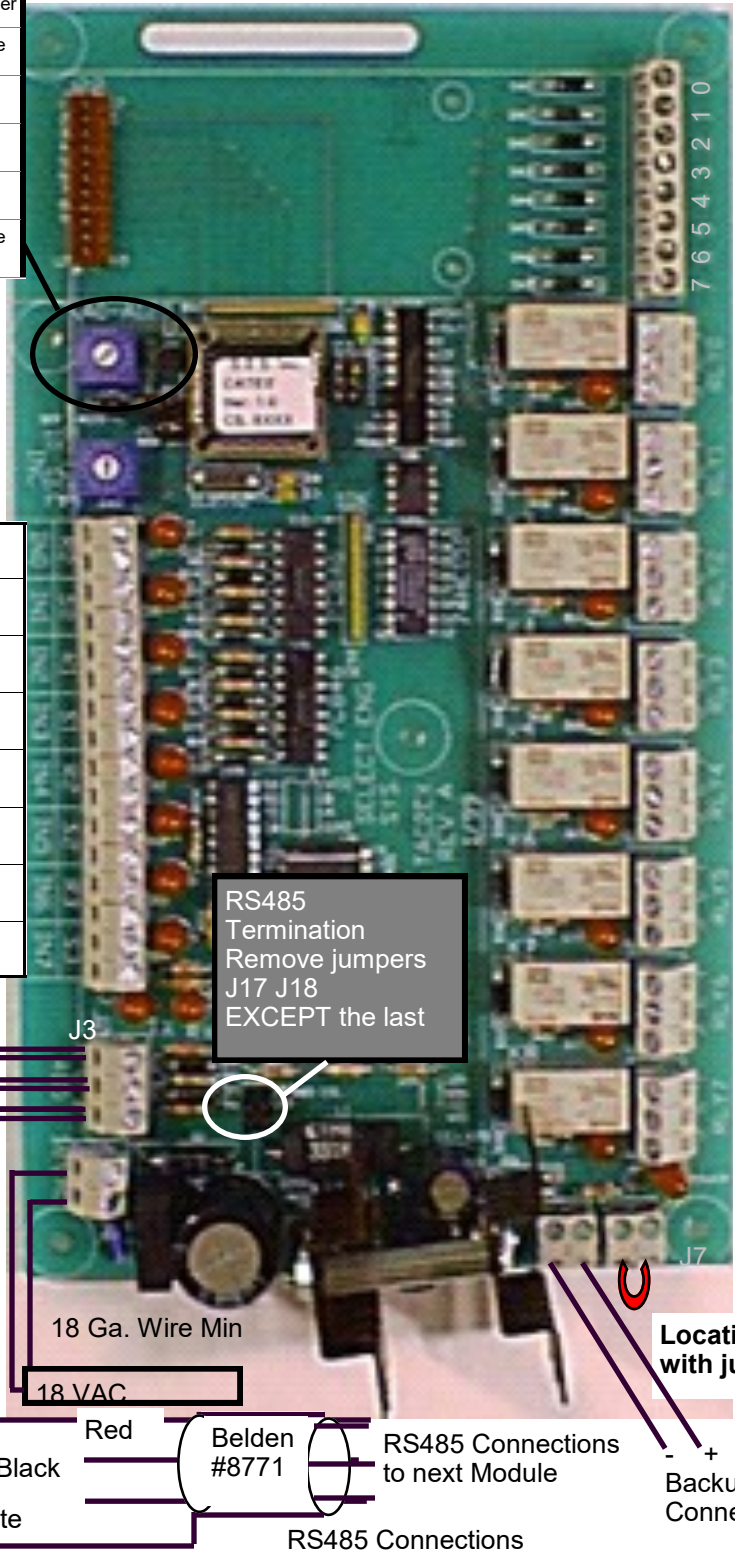

Logical low outputs for each reader . May be used with card readers to provide additional acceptance info. Outputs 0, 2, 4, 6 follow the entrance open relays.

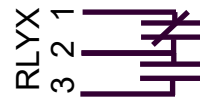

1-2 = N.C.
2-3 = N.O.

Relay outputs rated at 3 amps
24v ac/dc

Relay Outputs Entr. indicated follows

(SW1) Entrance	Relay	Function
5, 9, 13	RLY0	Entr. Control
5, 9, 13	RLY1	Alarm Shunt
6, 10, 14	RLY2	Entr. Control
6, 10, 14	RLY3	Alarm Shunt
7, 11, 15	RLY4	Entr. Control
7, 11, 15	RLY5	Alarm Shunt
8, 12, 16	RLY6	Entr. Control
8, 12, 16	RLY7	Alarm Shunt



RS485 Connections

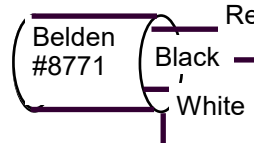

Connect Shields together and to Ground at CAT Series end ONLY

RS485 Termination Remove jumpers J17 J18 EXCEPT the last

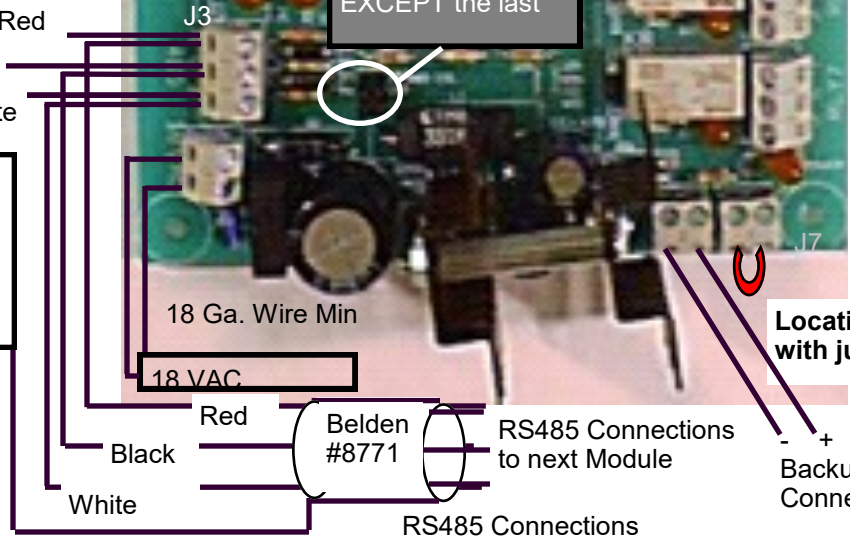

Location of J7 with jumper

Backup Battery Connections

CAT Series Auxiliary 4 Reader Module

INDEX

Board Address	5
Cabinet Size, Type	4
Code Addressing	5
Description	4
Fail Safe Configuration	5,7
Individual Relay Times	10
Index	11
Jumper, Relay	5,7
Power Connections	8
Programming Individual Relay Times	10
Relay Code Addressing	5
Relay Code Setting	5
Relay Timing	6
Relay Rating	4
RS485 Connections	8
RS485 Wire type	8
Size	4
Terminal Locations	9
Wire Type	8

Switch Position	Relay activate Time
0	2 sec
1	10 sec
2	20 sec
3	30 sec
4	40 sec
5	50 sec
6	60 sec
7	70 sec
8	80 sec
9	90 sec
A	100 sec
B	110 sec
C	120 sec
D	130 sec
E	140 sec
F	150 sec

Terminal ID	Relay Activated
IN0	R0
IN1	R1
IN2	R2
IN3	R3
IN4	R4
IN5	R5
IN6	R6
IN7	R7

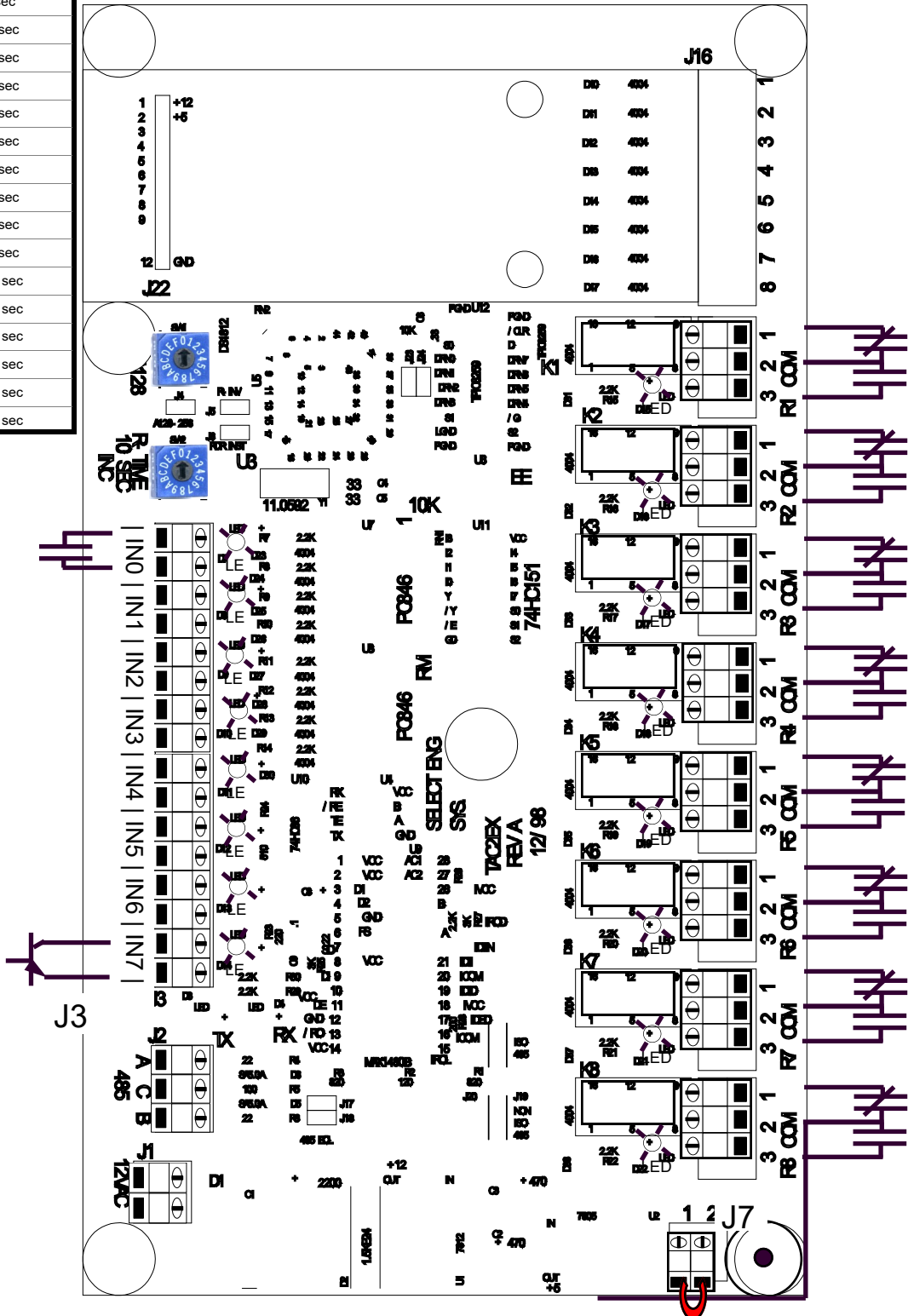

Location of J7 with jumper

CAT Series Auxiliary 4 Reader Module

“BETTER TECHNOLOGY MAKES BETTER SYSTEMS”

